

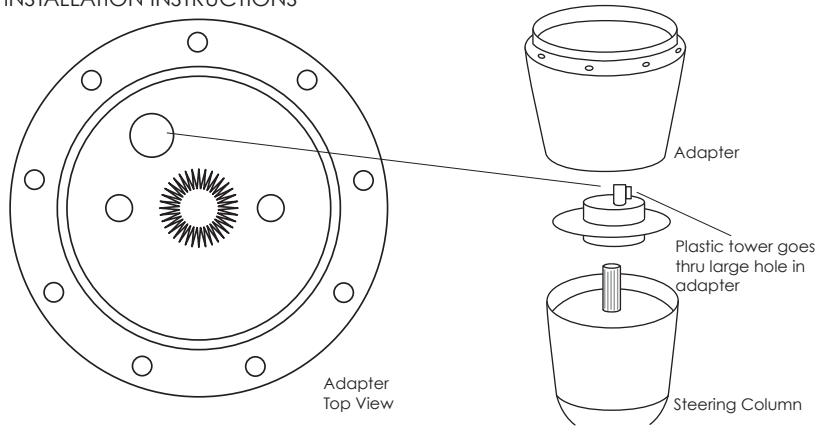

BEFORE YOU BEGIN

Remove original steering wheel. Turn wheels to a straight-ahead position. Remove original horn button or center pad and disconnect horn wire at horn button. Remove horn wire at column by pushing in and turning on the wire post. Remove the steering shaft nut. Use a steering wheel puller to remove wheel.

D-SHAPED STEERING WHEEL INSTALLATION INSTRUCTIONS



1. INSTALL COLUMN ADAPTER

Align horn-post hole on adapter to horn wire connection post on column and slide adapter on shaft with one of the mounting holes at the 12 o'clock position. Replace steering shaft nut and hand tighten, do not torque yet.

**Some aftermarket steering columns may not include this piece. This can be purchased from any GM dealer, AC Delco #26047013*

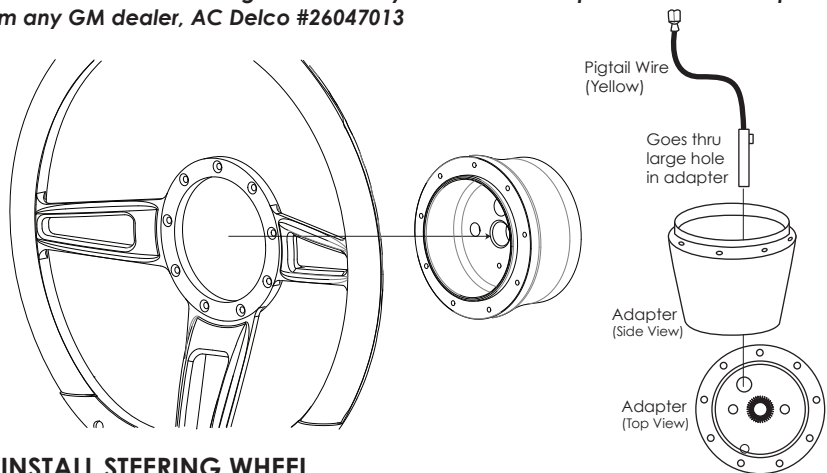

3. INSTALL STEERING WHEEL

Position steering wheel on adapter and install nine 8-32 flathead screws, tighten down steering wheel. Check the steering wheel to make sure it is straight. To adjust, remove the assembly (steering wheel & adapter) and index the adapter on the splined shaft. Once straight, torque steering shaft nut to 20-25ft. lbs.

Non-Billet Specialties Adapter

Billet Specialties steering wheels are drilled and counter-sunk to work with Billet Specialties adapters and use 8-32 hardware. Some aftermarket adapters are supplied with 10-32 hardware. On such applications the hardware must be changed to 8-32.

2. INSTALL LEATHER SECTIONS

Carefully place the leather segment into the recessed area. Start the 8-32 flat head screws in each hole by hand evenly before tightening.

DO NOT OVERTIGHTEN! This will damage the half-wrap.

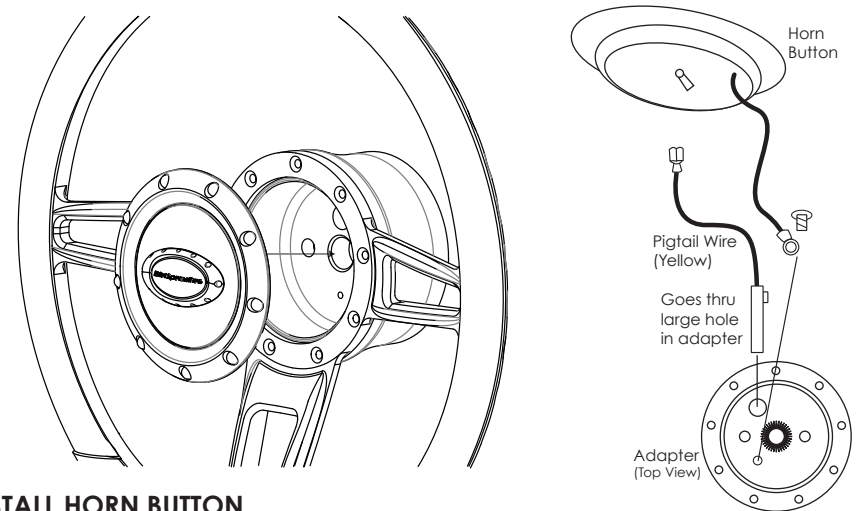

4. INSTALL HORN BUTTON

Install horn wire to post on column by pushing in and twisting to lock it in. The horn wire is not supplied with some aftermarket columns, but is available as a replacement part from Billet Specialties - #RP2510.

Attach black ground wire on back of the horn button to the 8-32 tapped hole in adapter using the supplied 8-32 x 1/4" Phillips screw. Install the spade connector on column horn wire to center tab on the back of the horn button.

Important: Lube O-ring on horn button and push horn button into bore of adapter.